



YOUR BUSINESS PARTNER
IN MINING AND PROCESS SOLUTIONS

SUCCESSFUL PROJECT HIGHLIGHTS - 2023

www.ManhattanCorp.com

YOUR BUSINESS PARTNER IN MINING AND PROCESS SOLUTIONS

YOUR BUSINESS PARTNER IN MINING AND PROCESS SOLUTIONS

MANHATTAN VOTED AS ONE OF SOUTH AFRICA'S TOP MINING SERVICE PROVIDERS

4 years running



YOUR BUSINESS PARTNER IN MINING AND PROCESS SOLUTIONS

TWO-STAGE 150 TPH LITHIUM DMS PLANT - 600 TPH Front End, Drying and packing stations, MCC units, Turnkey Design & Supply from ROM to Packaged Final Product



Concept Development, Laboratory Testwork. Design and Manufacture. Logistics, Installation and Commissioning.

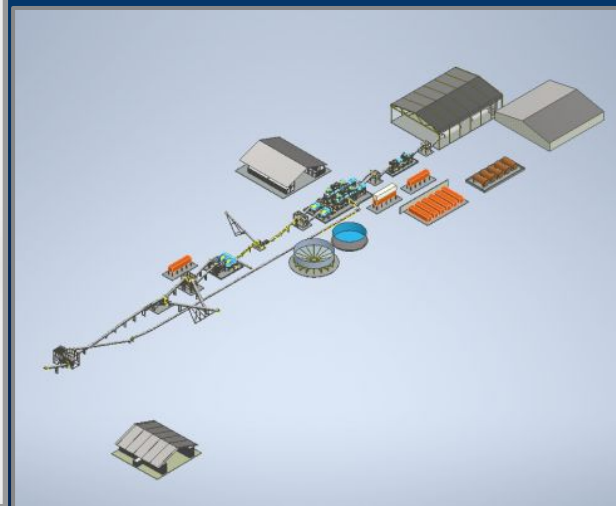

Civil and Geotechnical Design
Project Management
Electrical Design and Installation

YOUR BUSINESS PARTNER IN MINING AND PROCESS SOLUTIONS

25 000TPM TURNKEY GOLD PLANT – ZIMBABWE



Turnkey Design
Procurement
Engineering
Shipment, Installation & Commissioning

YOUR BUSINESS PARTNER IN MINING AND PROCESS SOLUTIONS

www.ManhattanCorp.com

25 000TPM TURNKEY GOLD PLANT – ETHIOPIA



Turnkey Design
Procurement, Engineering, Shipment
Installation & Commissioning

YOUR BUSINESS PARTNER IN MINING AND PROCESS SOLUTIONS

www.ManhattanCorp.com

TURNKEY PLATINUM PROCESSING PLANTS



- Assessed and audited by Manhattan metallurgical and design team
- Manhattan provides services in test work, design, construction and implementation of projects in the PGM sector, with process plants customised specifically to the ore-body
- Manhattan also implements plant modifications to increase recovery and throughput, design and construction of mining infrastructure and electrical and control systems to optimise process and operations

YOUR BUSINESS PARTNER IN MINING AND PROCESS SOLUTIONS

TURNKEY COAL PLANTS – DESIGN REFURBISH OR MANUFACTURE NEW



Assessed and audited by Manhattan processing and design team

- 50tph Wash Plant - 100tph Drum Plant - 200tph Wash Plant
- Bradford Breaker Crushing Plants
- Drum Separator Plants
- HMS – Jigging – Spiral plants

YOUR BUSINESS PARTNER IN MINING AND PROCESS SOLUTIONS

ALLUVIAL GOLD PLANT – PLANT AUDIT, SUDAN



Inspected
Secured samples for metallurgical tests
Presented proposal and recommendations on process improvements

YOUR BUSINESS PARTNER IN MINING AND PROCESS SOLUTIONS

16 X 30 FT SAG MILL – URANIUM, SOUTH AFRICA



Refurbishment
Logistics, Installation and Commissioning

YOUR BUSINESS PARTNER IN MINING AND PROCESS SOLUTIONS

www.ManhattanCorp.com

TANTALITE PLANT – MOZAMBIQUE



Dismantle
Design, Refurbish and Manufacture
Re-engineer
Project Management
Logistics, Installation and Commissioning

YOUR BUSINESS PARTNER IN MINING AND PROCESS SOLUTIONS

www.ManhattanCorp.com

4MVA STANDBY POWER PLANT - GOLD, SOUTH AFRICA



Turnkey Supply
Project Managed
Manufactured
Installed & Commissioned

YOUR BUSINESS PARTNER IN MINING AND PROCESS SOLUTIONS

www.ManhattanCorp.com

SILOS - SODIUM SULPHATE & AMMONIUM SULPHATE, SOUTH AFRICA

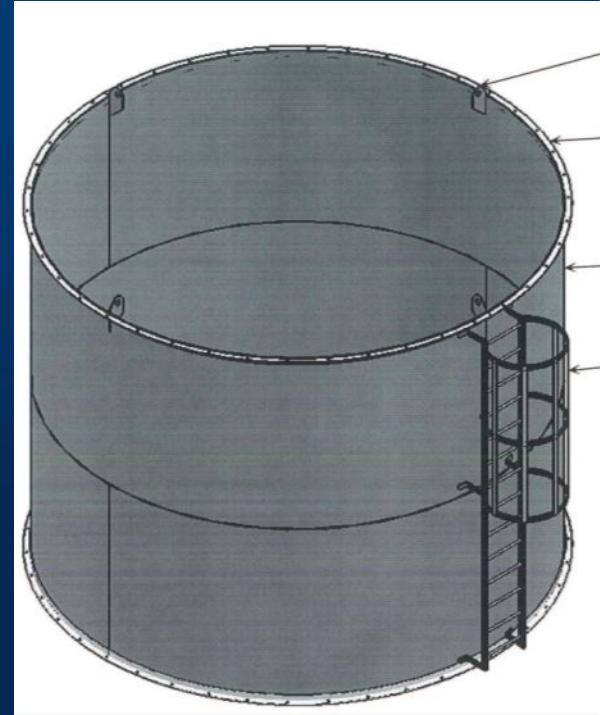
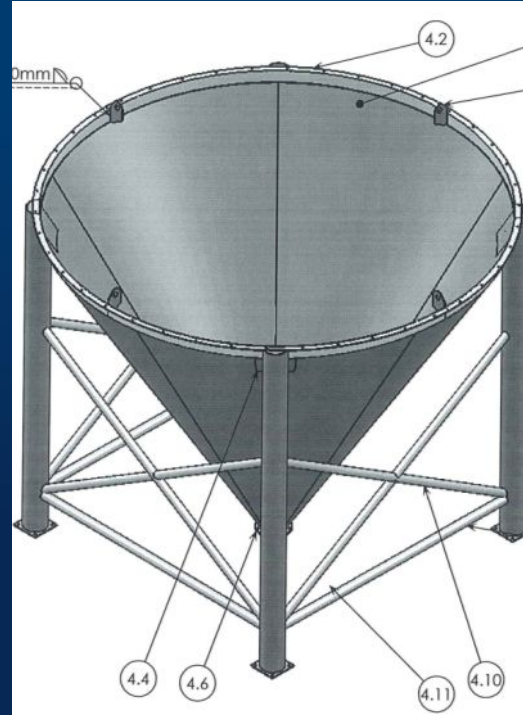
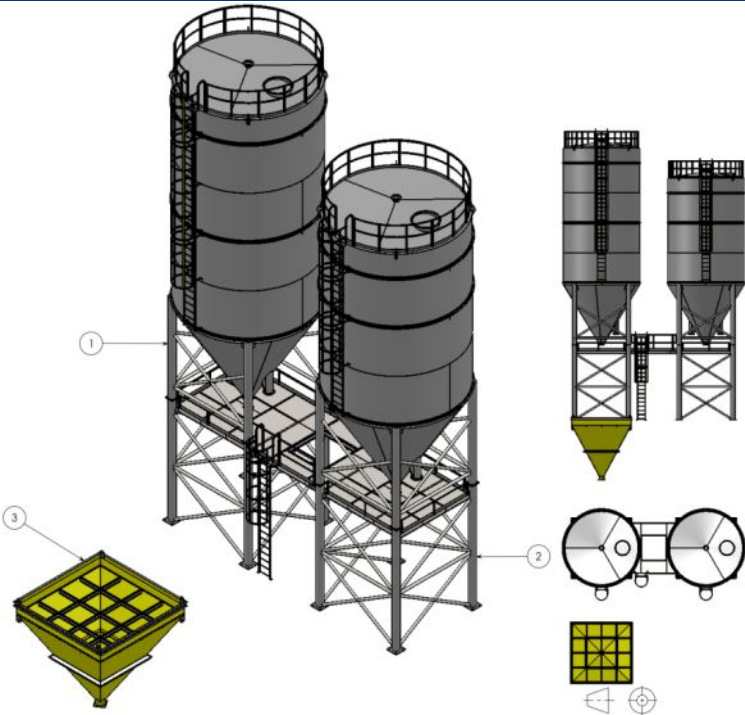

Design and Manufacture
Project Management
Logistics, Installation and Commissioning

YOUR BUSINESS PARTNER IN MINING AND PROCESS SOLUTIONS

9x12 FT BALL MILL - CHROME, ZIMBABWE



Re engineering / Refurbishment of Ball Mill
Liner Installation
Logistics, Installation and Commissioning

YOUR BUSINESS PARTNER IN MINING AND PROCESS SOLUTIONS

UNDERGROUND GOLD MINE – SOUTH AFRICA



UNDERGROUND MINING , PROCESS PLANT, HEAP LEACH AND GEOLOGY MANAGEMENT

Feasibility Study

Resource upgrade, and detailed plant design for a 300 000 tpa turnkey operation.

Underground development – shafts refurbishment, infrastructure, Mining machinery acquisition, Process Plant construction, TSF construction and commissioning.

YOUR BUSINESS PARTNER IN MINING AND PROCESS SOLUTIONS

CRUSHING PLANT - DIAMONDS, ZIMBABWE



Design and Manufacture
Project Management
Logistics, Installation and Commissioning

YOUR BUSINESS PARTNER IN MINING AND PROCESS SOLUTIONS

www.ManhattanCorp.com

DESANDING PLANT – BEACH SAND RECLAMATION, MOZAMBIQUE



Design
Engineering and Manufacturing
Supply

YOUR BUSINESS PARTNER IN MINING AND PROCESS SOLUTIONS

www.ManhattanCorp.com

VARUNO DIAMOND MINE – SOUTH AFRICA



3 600 000 tpa Diamond Operation

6 x 40t ADT's, 6 x CAT 966 Front End Loaders, 1 x 475 Komatsu Dozer, 1 x D9 Cat Dozer, 1 x D10 Cat Dozer, 3 x Excavators (30-85t), 3 x Trommel – Spyder / Warrior Mobile In-Pit Screens, with mobile de-sanders

6 x Rotary Pan Plants

30 tph Dense Medium Separation Plant

Modular X-Ray Recovery Plant

YOUR BUSINESS PARTNER IN MINING AND PROCESS SOLUTIONS

LYCIUM DIAMOND MINE – SOUTH AFRICA



1,800,000 tpa Process Plant and Mining Operation Development

Trommel Screens, De-sander Units, Mobile In-Pit Screens

Rotary Pan Plants

4 x 40t ADT's, 4 x 966 Front End Loaders, 2 x D9 Dozers, 1 x 330D Excavator

YOUR BUSINESS PARTNER IN MINING AND PROCESS SOLUTIONS

OCTO DIAMOND MINE – SOUTH AFRICA



4 800 000 tpa Process Plant and Mining Operation Development
Trommel Screens, De-sander Units, Mobile In-Pit Screens
13 Rotary Pan Plants
7 x 40t ADT's, 7 x 966 Front End Loaders, 2 x D9 Dozers, 2 x D10 Dozers, 385 & 365 Cat Excavators
30 TPH Dense Medium Separation Plant
Modular 8 unit X-Ray Recovery plant

YOUR BUSINESS PARTNER IN MINING AND PROCESS SOLUTIONS

SIMUS DIAMOND MINE – SOUTH AFRICA



2 400 000 tpa Process Plant and Mining Operation Development
Trommel Screens, De-sander Units, Mobile In-Pit Screens
Rotary Pan Plants

4 x 40t ADT's, 4 x Front End Loaders, 1 x D9 Dozer, 1 x D10 Dozer, 2 x 330D Excavators

YOUR BUSINESS PARTNER IN MINING AND PROCESS SOLUTIONS

2 300 000 TONS PER ANNUM DIAMOND MINE – ZIMBABWE



Construction of a 2 300 000 tpa Process Plant
65 tph Dense Medium Separation Plant
Screening Plant
X-Ray Recovery

YOUR BUSINESS PARTNER IN MINING AND PROCESS SOLUTIONS

MATERIALS HANDLING – GHANA



Structural Design and Manufacture
Project Management
Commissioning

YOUR BUSINESS PARTNER IN MINING AND PROCESS SOLUTIONS

876 000 TONS PER ANNUM DIAMOND PROCESS PLANT – TANZANIA



864,000 TPA Diamond Process Plant

Design, Construction, Shipment and Implementation

Scrubbing, Mobile Rotary Pan and Screening Plants

Design, Construct, Install, Commission, Logistics Support, and Management Infrastructure

Development

YOUR BUSINESS PARTNER IN MINING AND PROCESS SOLUTIONS

DIAMOND PLANT – AFRICA



200t/h Dense Medium Separation Diamond Recovery Plant
Scrubbing, DMS, XRay recovery
Turnkey Supply, Installed and Commissioned

YOUR BUSINESS PARTNER IN MINING AND PROCESS SOLUTIONS

MATERIALS HANDLING – COAL, SOUTH AFRICA



Pit to surface stockpile Project - Designed, Manufactured, Installed and Commissioned
1000 t/h Overland and Spreader Conveyor System, 600 t/h Garland Conveyor System

YOUR BUSINESS PARTNER IN MINING AND PROCESS SOLUTIONS

PROCESS SOLUTION – URANIUM, AFRICA



Ball Mill to Process Pyrolusite
Turnkey Supply and Refurbishment, Installed and Commissioned

YOUR BUSINESS PARTNER IN MINING AND PROCESS SOLUTIONS

MODULAR X-RAY PLANT- DIAMONDS, AFRICA



Designed, Manufactured, Installed and Commissioned
8 XRay Units
Sort Room with Drying and Glove Box facilities

YOUR BUSINESS PARTNER IN MINING AND PROCESS SOLUTIONS

7 000 000 TONS PER ANNUM SCREENING PLANT – AFRICA



Designed, Manufactured, Installed and Commissioned

YOUR BUSINESS PARTNER IN MINING AND PROCESS SOLUTIONS

www.ManhattanCorp.com

864 000 TONS / AN. CRUSHING, DIAMOND DMS & XRAY RECOVERY PLANT – AFRICA



Turnkey Supply: Designed, Engineered, Installed and Commissioned
After Sales Support

YOUR BUSINESS PARTNER IN MINING AND PROCESS SOLUTIONS

THICKENER FEED TANKS – GOLD, SOUTH AFRICA



Turnkey Supply
Designed, Manufactured, Installed and Commissioned

YOUR BUSINESS PARTNER IN MINING AND PROCESS SOLUTIONS

www.ManhattanCorp.com

300 000 TONS PER ANNUM MODULAR GRAVITY GOLD PLANT – AFRICA



Turnkey Supply: Designed, Manufactured, Installed and Commissioned

YOUR BUSINESS PARTNER IN MINING AND PROCESS SOLUTIONS

PLATINUM PROCESSING PLANT – AFRICA



Turnkey Supply: Materials Handling, Crushing and Screening
Designed, Manufactured, Installed and Commissioned

YOUR BUSINESS PARTNER IN MINING AND PROCESS SOLUTIONS

www.ManhattanCorp.com

5MVA STANDBY POWER PLANT - CHROME, SOUTH AFRICA



Turnkey Supply:
Project Managed, Manufactured, Installed & Commissioned

YOUR BUSINESS PARTNER IN MINING AND PROCESS SOLUTIONS

IN-PIT SCREENING PLANTS - DIAMONDS, SOUTH AFRICA



Supply of 6 in-pit screening plants
Project Management, Logistics and Commissioning

YOUR BUSINESS PARTNER IN MINING AND PROCESS SOLUTIONS

MILL DISMANTLING & REFURBISHMENT – SOUTH AFRICA AND GHANA



Platinum, Gold, Chrome

4 x 5.2MW, 32 x 16ft SAG Mills, 3 x 2.6MW, 16 x 22ft Ball Mills

Turnkey Project: Refurbishment, Logistics, Sea Freight, Installation and Commissioning

YOUR BUSINESS PARTNER IN MINING AND PROCESS SOLUTIONS

4MVA COPPER SMELTING PLANT - AFRICA



Turnkey Supply
Installed & Commissioned

YOUR BUSINESS PARTNER IN MINING AND PROCESS SOLUTIONS

www.ManhattanCorp.com

600 000 TONS PER ANNUM PLATINUM PROCESSING PLANT



EPCM Contract and After Sales Support

YOUR BUSINESS PARTNER IN MINING AND PROCESS SOLUTIONS

www.ManhattanCorp.com

NEW GIRTH GEAR AND PINION FOR 16x20 FT / 2300KW – MIDDLE EAST



Design and manufacture of new girth gear and pinion
Non destructive tests and heat treatment
Installation

YOUR BUSINESS PARTNER IN MINING AND PROCESS SOLUTIONS

www.ManhattanCorp.com

300 TONS PER HOUR MOBILE BELT CONVEYOR – COAL, SOUTH AFRICA



Design of Belt Conveyor
Engineering and Manufacturing
Electrics
Transport to Site
Installation and Commissioning

YOUR BUSINESS PARTNER IN MINING AND PROCESS SOLUTIONS

9x10 FT BALL MILL - GOLD, MALI



Supply & Refurbishment of Ball Mill
Liner Installation
Logistics, Installation and Commissioning

YOUR BUSINESS PARTNER IN MINING AND PROCESS SOLUTIONS

STATIC & MOVABLE GRASSHOPPER MATERIALS HANDLING SYSTEM – COAL



Multiple grass-hopper conveyors and one slewing/stacking conveyor for 25000 tons Uranium dumps
Turnkey Supply
Design
Manufacture
Logistics

YOUR BUSINESS PARTNER IN MINING AND PROCESS SOLUTIONS

18 FT. DIAMETER PAN PLANTS – BUILT NEW - DIAMONDS



Mobile 18ft. Diameter Pan Plants

With Dewatering screen, feed hopper, feed conveyor and waste conveyor

Turnkey Supply - Design - Manufacture - Delivery

Zimbabwe, Russia, Angola, DRC, Lesotho, South Africa – some of the destinations for Manhattan Rotary Pan Plants

YOUR BUSINESS PARTNER IN MINING AND PROCESS SOLUTIONS

65 TPH DMS PLANT – DESIGN- BUILD- INSTALL - DIAMONDS



- 65 tph DMS Plant- with 150 TPH Scrubber front end, Flow Sort diamond Recovery
- Design – Build – Install - Commission
- Manhattan supplies from 5 TPH to 200 TPH + DMS units, Modular design
- Scrubbing Front End to suit
- Flow Sort or Bourevestnik Final Recovery solutions

YOUR BUSINESS PARTNER IN MINING AND PROCESS SOLUTIONS

65 TPH DMS PLANT – DESIGN- BUILD- INSTALL – ZIMBABWE - DIAMONDS



- 150 TPH Scrubber Plant
- Design – Build – Install - Commission
- Manhattan supplies from 5 TPH to 400 TPH Scrubber Solutions

YOUR BUSINESS PARTNER IN MINING AND PROCESS SOLUTIONS

30 TPH DMS PLANTS – DESIGN- BUILD- INSTALL - DIAMONDS



- 30 tph DMS Plant- Northern Cape South Africa
- Design – Build – Install - Commission

YOUR BUSINESS PARTNER IN MINING AND PROCESS SOLUTIONS

5 TPH ROTARY DRYER- GRAPHITE MINE- NAMIBIA



- Rotary Dryer, 5 TPH
- Includes Feed and Product Conveyors
- Civil Design and Steel Bending Schedules
- Process Design, Supply
- Freight & Logistics

YOUR BUSINESS PARTNER IN MINING AND PROCESS SOLUTIONS

5 TPH & 25 TPH FILTER PRESS UNITS – NAMIBIA & SOUTH AFRICA



- 5 TPH PLC controlled automatic Filter Press
- 25 TPH vibrate clean function- PLC controlled automatic Filter Press
- Hydraulic Operation
- Spares
- Civil Design, Process Design, Supply
- Freight & Logistics

YOUR BUSINESS PARTNER IN MINING AND PROCESS SOLUTIONS

CONVEYOR PROJECTS DESIGNED, MANUFACTURED, INSTALLED



YOUR BUSINESS PARTNER IN MINING AND PROCESS SOLUTIONS

CRUSHING PLANT: GRIZZLY, JAW, CONE, SCALP SCREEN, CONVEYORS: AFRICA



YOUR BUSINESS PARTNER IN MINING AND PROCESS SOLUTIONS

JIGGING PLANTS: DIAMONDS, TANTALITE, COPPER, CHROME: MOZAMBIQUE, DRC, GUINEA, ANGOLA

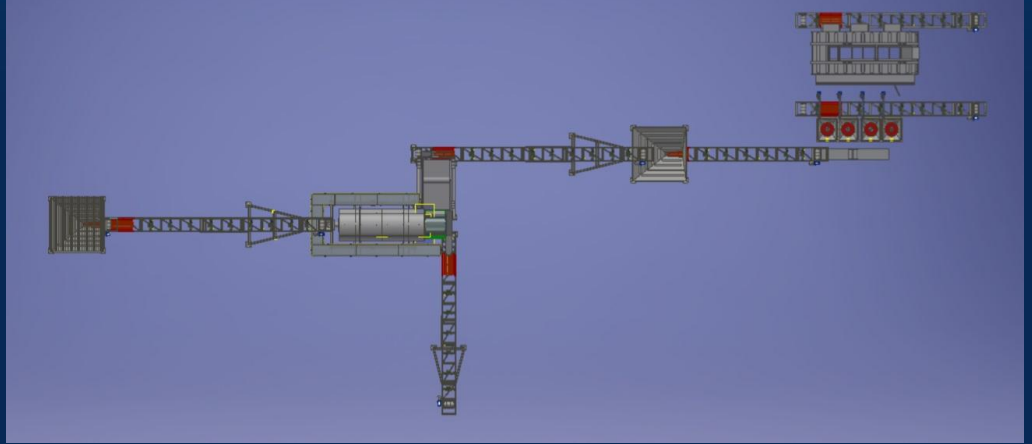
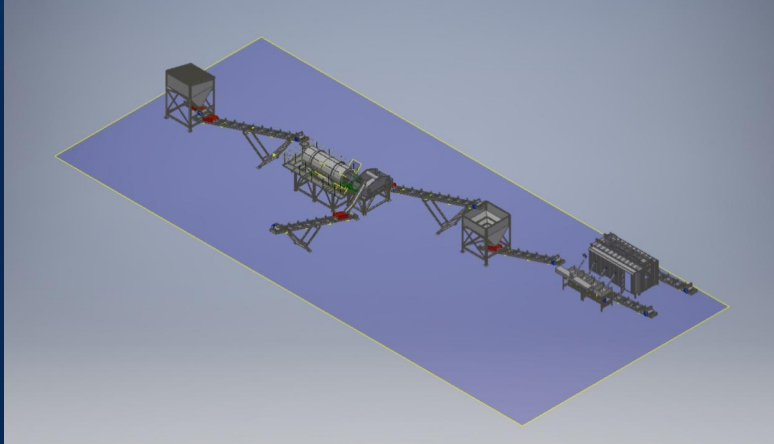

YOUR BUSINESS PARTNER IN MINING AND PROCESS SOLUTIONS

HEAVY DUTY BARREL SCREENS: 500-800 TPH: OPEN CAST ALLUVIAL DIAMOND PROJECT RSA



YOUR BUSINESS PARTNER IN MINING AND PROCESS SOLUTIONS

HIGH CAPACITY DESANDING PLANTS- MOZAMBIQUE, RSA AND ZIMBABWE



YOUR BUSINESS PARTNER IN MINING AND PROCESS SOLUTIONS

AGITATOR AND GOLD LEACHING PLANTS; 3KTPM TO 200KTPM- PROJECTS IN RSA, ZIMBABWE, ETHIOPIA, TANZANIA, MALI, SIERRA LEONNE, MOZAMBIQUE

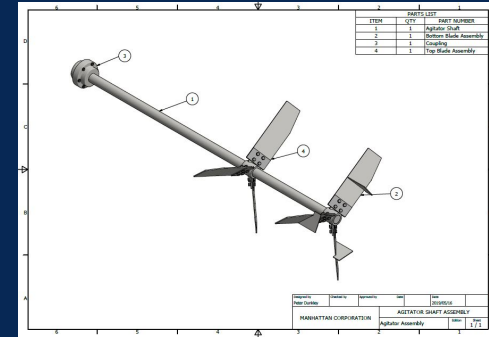
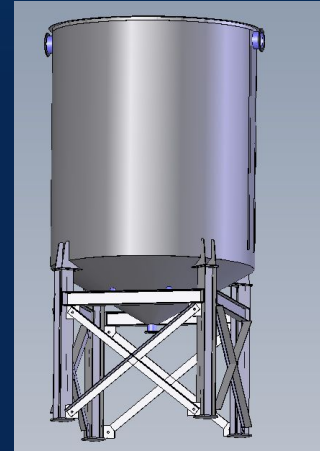
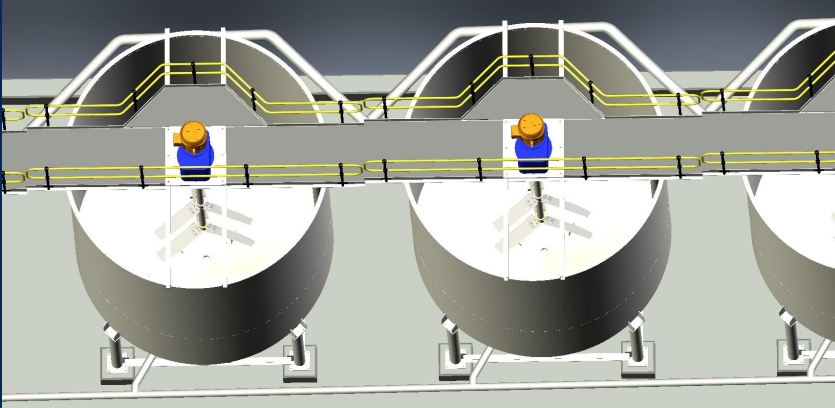
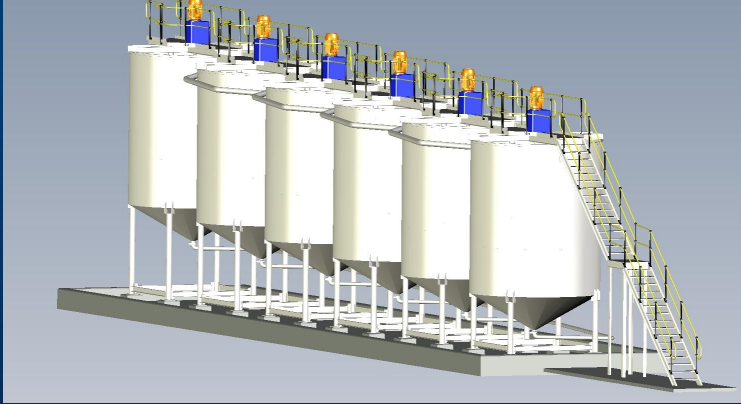

YOUR BUSINESS PARTNER IN MINING AND PROCESS SOLUTIONS

MINING AND MINERAL PROCESSING EQUIPMENT CATEGORIES

1. **Conveyors, Bucket Elevators & Conveying Systems**
2. **Crushers**
3. **Diesel Generators**
4. **Drying & Sintering Equipment**
5. **Electrical MCC circuits LT and HT**
6. **Feeders, Bins and Material Storage Systems**
7. **Filtering Equipment**
8. **Flotation Equipment (Tank & Column)**
9. **Gravity Recovery Equipment**
10. **Grinding Mills / Comminution systems**
11. **Laboratory Process Equipment**
12. **Magnetic Separation Equipment**
13. **Mineral Processing Plants**
14. **Process Equipment**
15. **Pumps & Spares**
16. **Rolling Stock, Locomotives, hoppers & support equipment**
17. **Sand Washing & Processing Equipment**
18. **Screens and screening plants**
19. **Tanks, Agitators, leaching systems**
20. **Thickeners and Water Recovery Systems**
21. **Transformers, Substations**
22. **Winches**
23. **Winders**

YOUR BUSINESS PARTNER IN MINING AND PROCESS SOLUTIONS

TURNKEY MINING AND MINERAL PROCESSING PLANT CATEGORIES

Turnkey & Process plant solutions offered by Manhattan, include :-

1. Lithium & Diamond Plants, Pans, Jigs, DMS, XRay, XRT, Front End Scrubbing, In-Pit mobile Screening, Static Screening, Power generation, Turnkey Project Establishment
2. Gold Plants, Cyanidation, Flotation, Crushing, Milling , Leaching, Elution, Gold Refining
3. Gold Plants, Free-gold recovery, Crushing, Scrubbing, Centrifuge, Trommel, Sluice, Gold Room
4. Coal Plants, Overland Conveyor with Mineral Sizing, Breakers, Granulating, Crushing, Drum, DMS, Jig, Spiral Upgrading/ washing
5. Conveying Systems, overland, static, stockpile, mobile, customized
6. Crushing Plants with Cone, Gyratory, Jaw, Impact, Roll, multistage & Single roll, hammer crushers
7. Flotation, gravity, magnetic separation, smelting
8. Leaching plants, Thickener plants, Agitated tank plants
9. Mineral Processing Plants- Enquirer for your need
10. Process Equipment- Over 20 mineral types supported by Manhattan
11. Sand Wash & Classification Plants
12. Screening plants
13. Turnkey mine establishment

YOUR BUSINESS PARTNER IN MINING AND PROCESS SOLUTIONS

CONTACT DETAILS

Manhattan Corporation Group

Tel: +27 (0)11 748 8800

Fax: +27 (0)11 748 8898

Mobile/ Whats App: +27 60 997 4509

Email: info@manhattancorp.com



Social Media: [@ManhattanProEng](#)

<https://twitter.com/ManhattanProEng>

<https://facebook.com/ManhattanProEng>

<https://instagram.com/ManhattanProEng>

www.ManhattanCorp.com
Turnkey Plants and Process Solutions

YOUR BUSINESS PARTNER IN MINING AND PROCESS SOLUTIONS

www.ManhattanCorp.com